

**TYPICAL INSTALLATION WITH MINIMUM CLEARANCES**

**ABOVE GROUND**

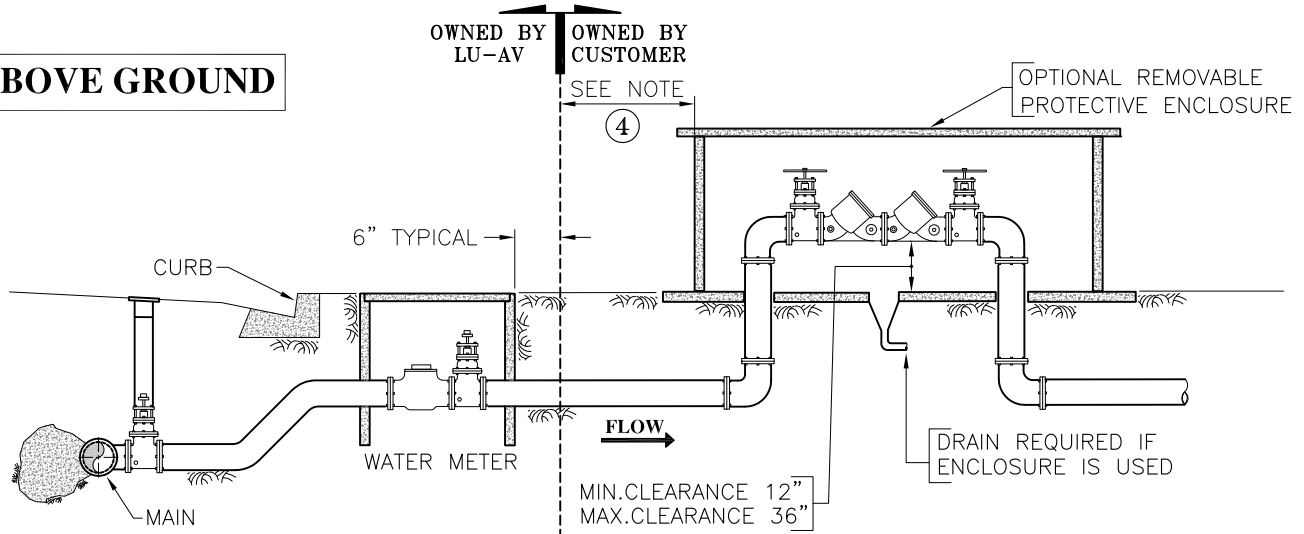

**PLAN VIEW**

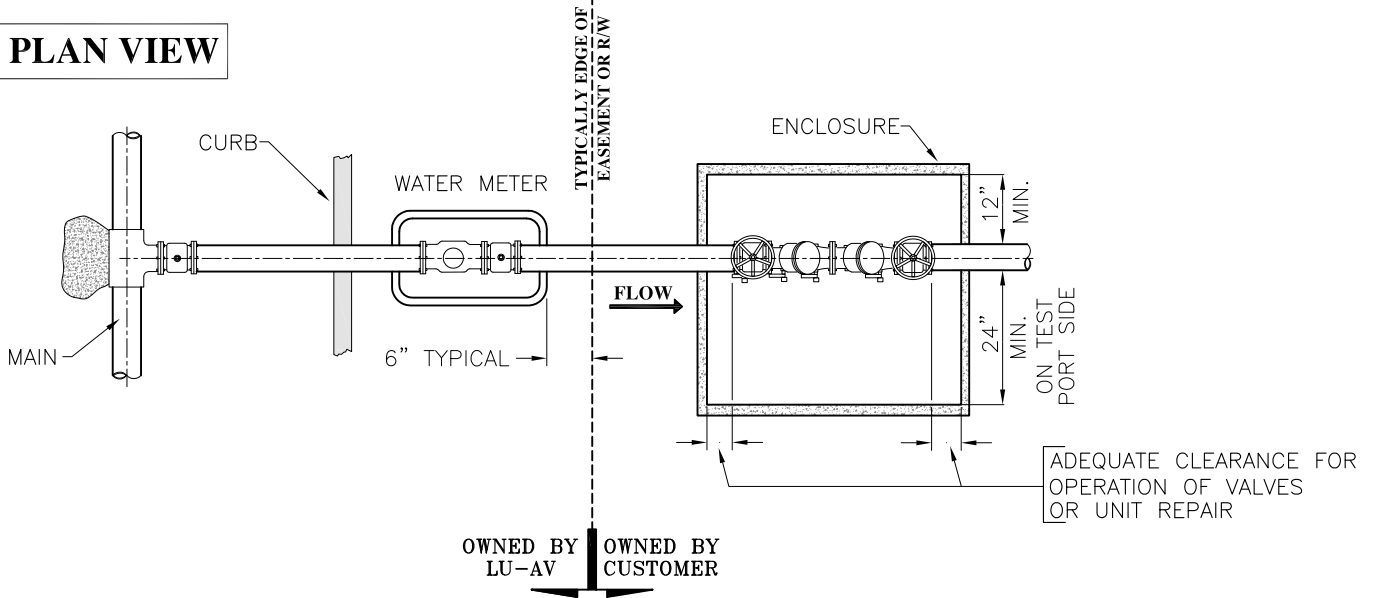

**NOTES:**

- ① Backflow prevention device shall be on the U.S.C. list of approved devices.
- ② Device must be certified and tested in place before being put in use. Device must be retested annually. (Lead free)
- ③ For questions concerning installation, operation & testing call the Cross-Connection Specialist at Liberty Utilities – Apple Valley.
- ④ Assembly shall be located within close proximity to R/W line or easement line on private property.
- ⑤ Freeze protection is required on all above ground assemblies

DWN	<b>G. AKOPYAN</b>	CTB	LU-AV-Const
CHK	<b>RRD / GJM</b>	DATE	<b>02/02/17</b>
SHEET	<b>1 OF 1</b>	SCALE	<b>None</b>
FILE	N:\CAD\AV\Standards\Rev 02-02-17\AV-311.dwg		

SUBJECT: STANDARD DRAWING

**DOUBLE CHECK VALVE ASSEMBLY**

**{ 2 1/2" & ABOVE }**

**LIBERTY UTILITIES - APPLE VALLEY**

21760 OTTAWA ROAD

APPLE VALLEY, CA 92307